



MADE IN CANADA

MOBILE SIGN

MOBILE SIGN WITH HEADER ASSEMBLY INSTRUCTIONS

1. Insert legs into base and tighten bolts.

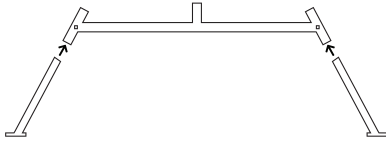

2. Insert 16" Tailstock into riser on sign base.

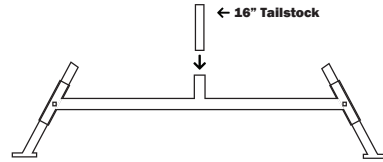

3. Place sign face on base and tighten moderately.

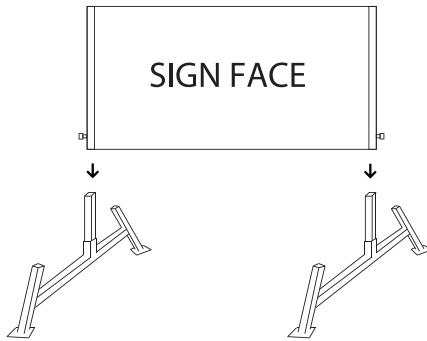

4. Insert tailstock approximately 5" into sides of header and tighten bolts. Then slide 2" spacer over receiving tubes.

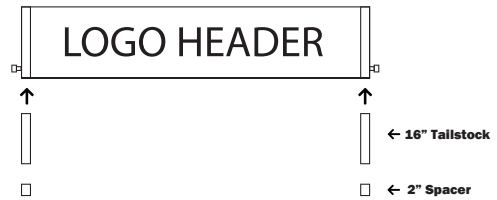

5. Insert header into sign frame (HEADER IS NOT FASTENED TO SIGN).

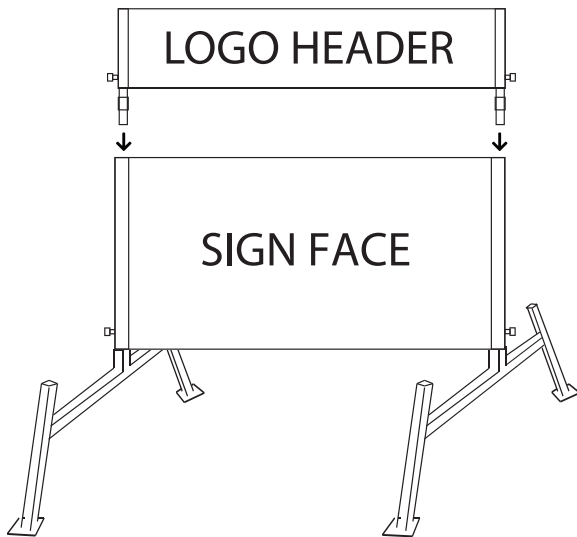

6. Adjust and level to desired height. Then anchor in place.

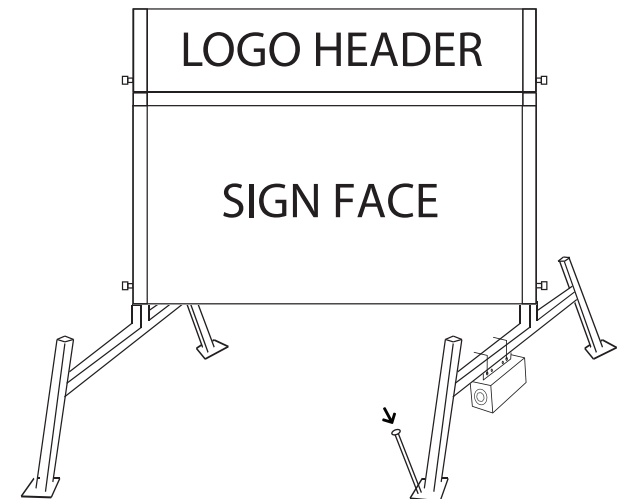

A 3/4in wrench and a hammer is required for assembly.

PARTS

- 1. Header
- 2. Sign Face
- 3. Sign Base
- 4. Legs
- 5. 16" Tailstock
- 6. 2" Spacer
- 7. Bolts
- 8. Anchor Rod (Optional)
- 9. Sign Weight Box (Optional)

